

## CONTENTS

(x1) Lighting Assembly

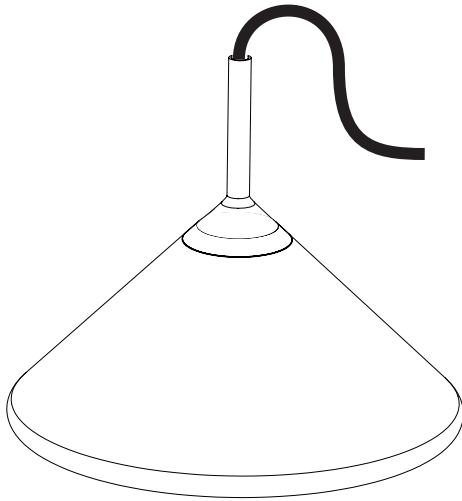

(x2) 8-32 Screw



(x7) Wago Connector



(x1) Driver

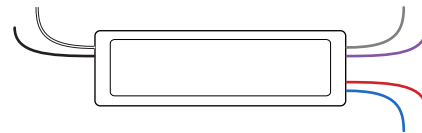

(x1) Canopy with Crossbar assembly

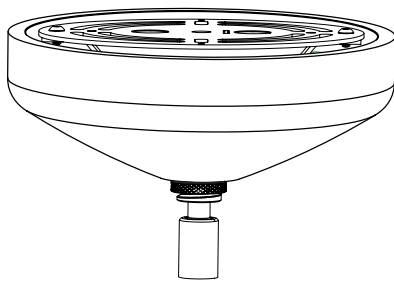

(x2) Toggle anchor  
On 240V fixtures only

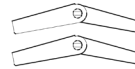

(x2) Wood screw  
On 240V fixtures only



(x2) Long 8-32 screw  
On 240V fixtures only



(x2) Metal screw  
On 240V fixtures only



## SAFETY INFORMATION

Suitable for damp locations  
Maximum ambient temperature: 25°C

## APOLLO PENDANT-CORD | INSTALLATION

---

*Note: Please contact a licensed electrician for installation. Ensure power is off during installation.*

01. Unscrew the hang-straight nut (A) from the canopy with crossbar assembly (B).

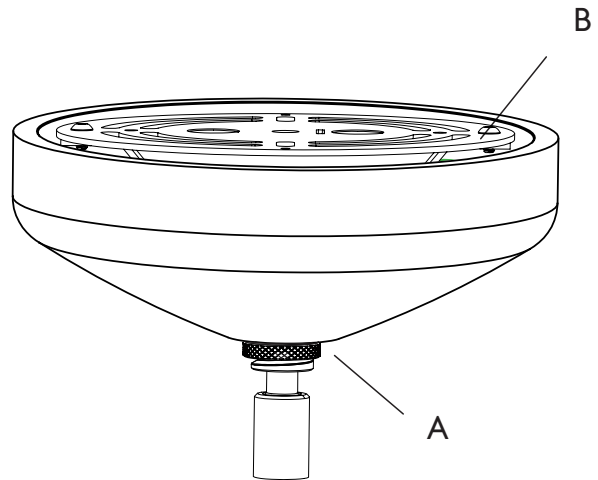

02. Raise the crossbar assembly (C) to junction box (D), and secure with #8-32 screws (E). Be sure to pull out the wires from the junction box, through the hole in the cross bar.

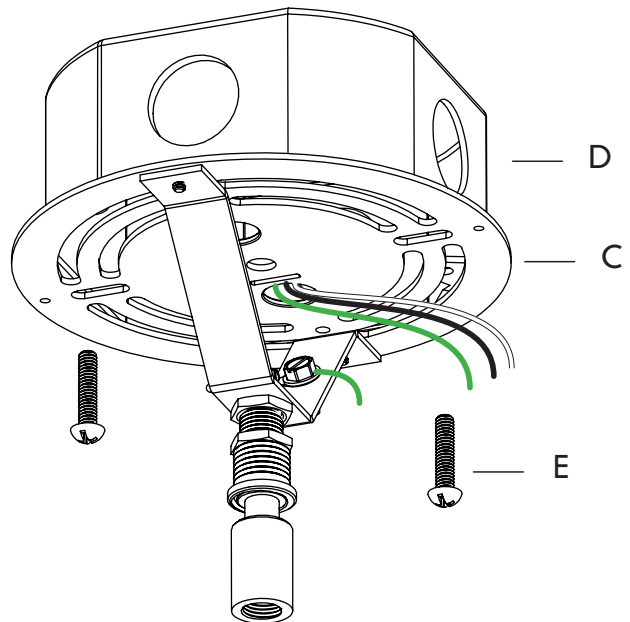

## APOLLO PENDANT-CORD | INSTALLATION

---

03. Thread the cord (F) through the hang-straight nut (A), canopy (G), and hang-straight (H).
04. Cut the cord to desired length of the fixture, strip the wires about 2.5in, and use a strain relief (I) to secure the cord.

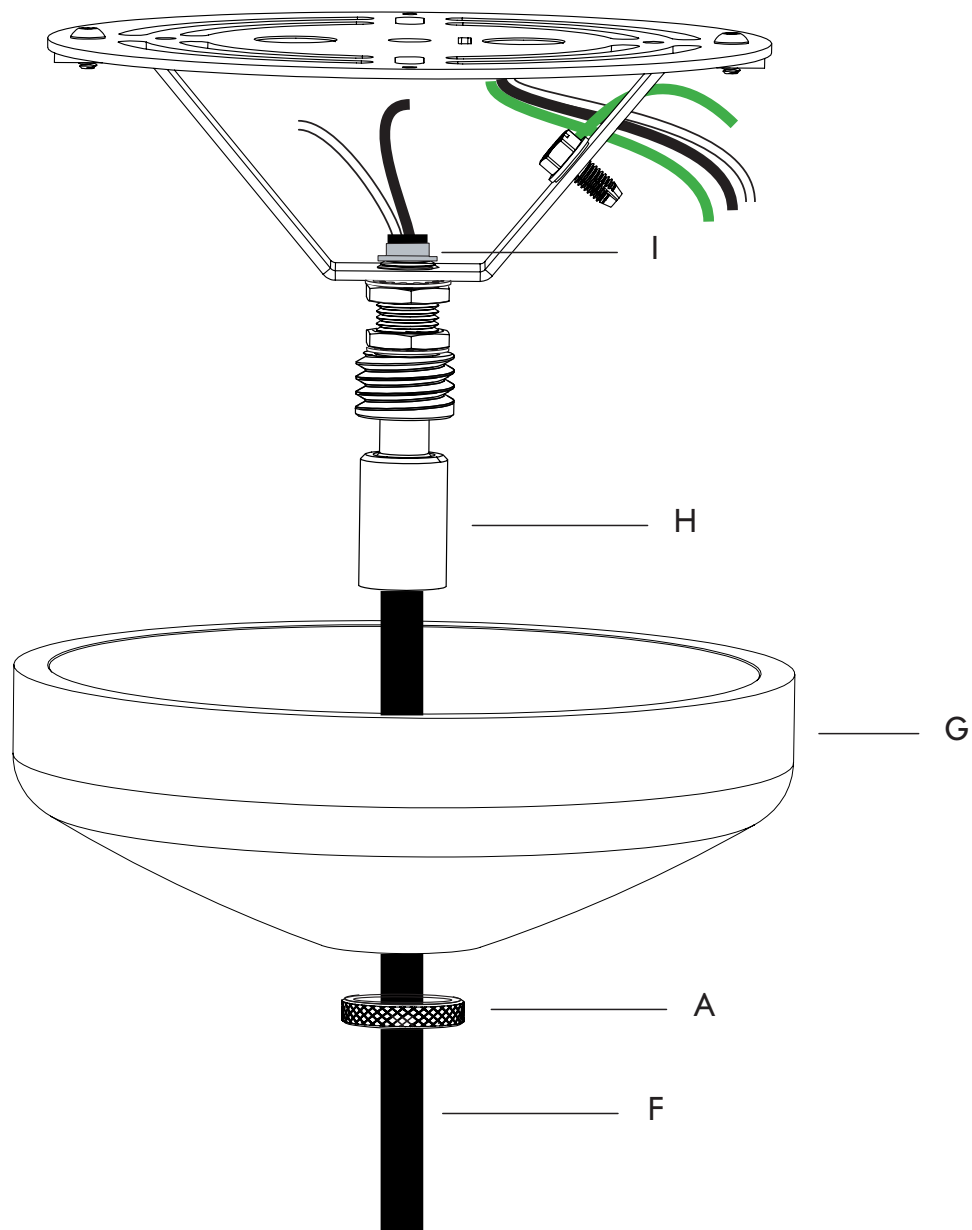

## APOLLO PENDANT-CORD | INSTALLATION

---

05. Fit the driver (J) into the space in the crossbar assembly (C).
06. Make the electrical connections between the lead AC wires and the driver using the provided wago connectors (K).
07. Connect the secondary wires to the fixture using the provided wago connectors (L)  
(Optional: Connect the 0-10V dimming wires (M) as needed)
08. Connect the ground wire (N) with the provided wago connector.
09. Tuck all wires into the crossbar assembly.

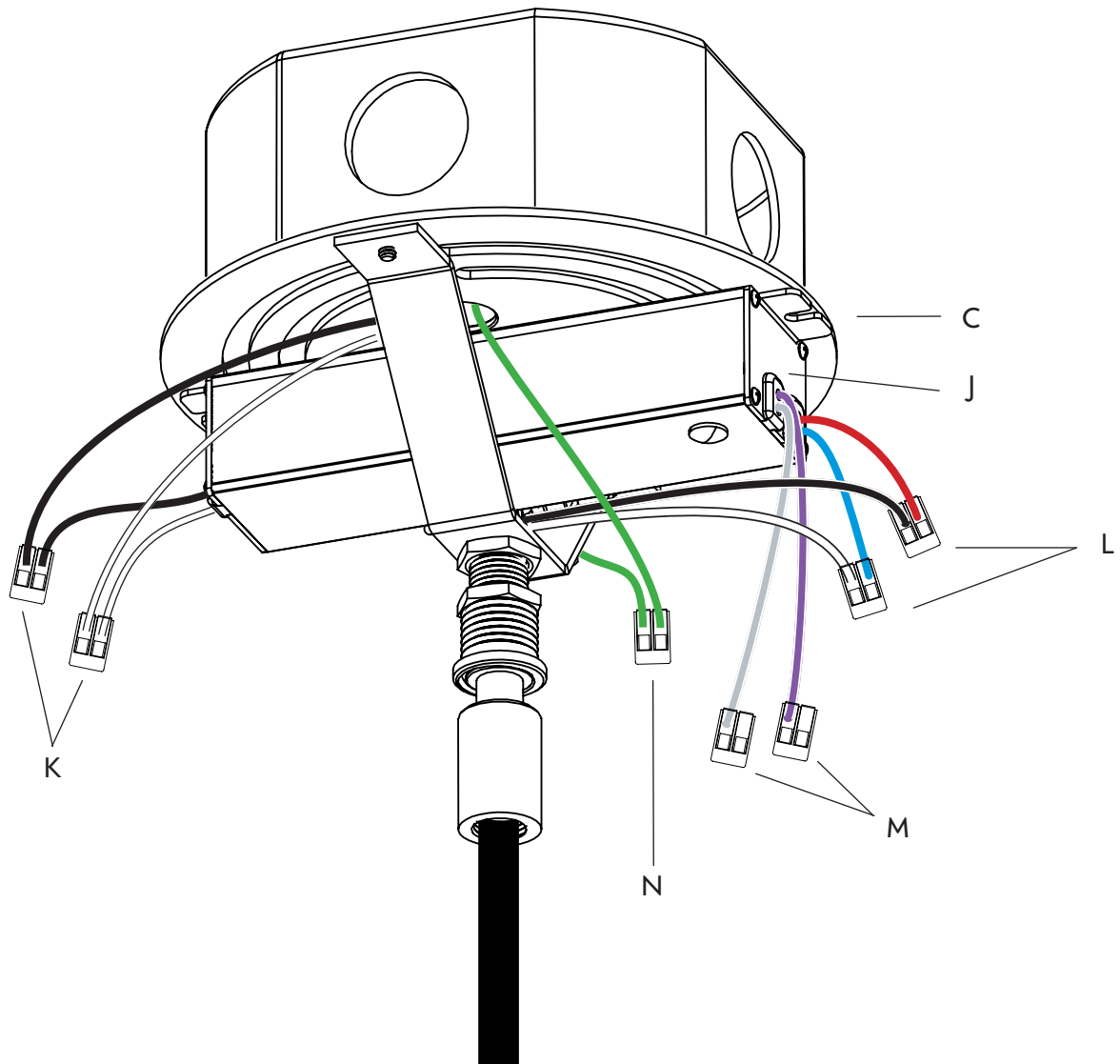

## CONTENTS

---

10. Once all the wires are connected and tucked in, raise the canopy (G) over the crossbar assembly, and secure it with the hang-straight nut (A).

